

## PARTS & INSTALLATION INSTRUCTIONS

### MEYER SNOW PLOW MOUNTING for 1988 & Later GMC and Chevrolet K Series (GMT 400) 4x4 Models

#### IMPORTANT NOTICE

**End user must be given this instruction sheet prior to delivery of this Snow Plow.**

The equipment you have just purchased should only be used on vehicles equipped with the Manufacturer's Snow Plow Preparation Packages. Snow Plowing without the original Snow Plow Preparation Package may damage your vehicle and the added weight to the equipment may impair the operation and control of the vehicle. Snow Plowing with a vehicle that the manufacturer does not recommend for that purpose may void your new vehicle warranty. If your vehicle is not originally equipped with the Snow Plow Package, additional parts may be necessary before snow plowing. Owners of these vehicles should consult their dealers before purchase or installation of such parts. CAUTION: the installation, on any vehicle, of these parts is not a full substitute for the original equipment Snow Plow Preparation Package.

**Warning: Lift Arm extends beyond bumper of vehicle. To minimize damage from a front-end collision, Lift Arm should be removed from vehicle when Snow Plow is removed.**

#### PARTS LIST

Item	Part No.	Qty.	Description		
	17089	1	MOUNTING CARTON		
1	11265	1	• Clevis Frame		
2	11542	1	• R.H. Strap		
3	11263	1	• L.H.Strap		
4	10514	1	• Lift Arm		
5	11544	2	• Receiver Tube Cap		
	08596	1	• HARDWARE BAG		
	10797	2	•• Spacer - Ref. SB 154R		
6	11006	2	•• Hinge Pin		
7	11291	2	•• Space Bar		
8	14595	1	•• Special Bolt (J-Bolt) 3/4-10		
9	20098	2	•• Bolt H 1/2-13 x 2-1/4" Gr.5		
10	20140	2	•• Bolt H 5/8-11 x 1-3/4" Gr.5		
11	20144	1	•• Bolt H 5/8-11 x 2-3/4" Gr. 5		
12	20146	2	•• Bolt H 5/8-11 x 3-1/4" Gr. 5		
13	20307	2	•• Locknut Esna 1/2-13		
14	20309	5	•• Locknut Esna 5/8-11		
15	20310	1	•• Locknut 3/4-10		
16	20355	4	•• Flatwasher 1/2"		
17	20357	1	•• Flatwasher 5/8		
18	22113	6	•• Bolt H M14 x 2 x 50mm Gr.8.8		
19	22123	1	•• Bolt H M14 x 2 x 140mm		
20	22140	7	•• Lockwasher- INT/EXT 9/16		
	21976	2	•• Battery Connectors		
21	21984	2	•• Hair Pin Cotter		
22	11255	1	LIFT FRAME (Tubular)		
	11" Sector		15" Sector		
Item	Part No.	Qty.	Part No.	Qty.	Description
	16505	1	16504	1	SECTOR - A-FRAME CARTON
	12326	1	12793	1	• Sector
23	13612	1	13608	1	• A- Frame
	07017	3	07017	4	• Trip Spring
	09916	1	09916	1	• Marker Kit
	08166	1	08341	1	• PLOW HARDWARE BAG
	09119	2	09119	1	•• Pivot Pin w/Cotter
24	11101	2	11101	2	•• Hinge Pin
25	22083	2	22083	2	•• Linch Pin
	09122	1	09125	1	•• King Bolt w/Locknut
	09124	3	09124	4	•• Eye Bolt w/Locknuts

Parts indented are included in the carton, bag or assembly under which they are indented. When ordering parts, furnish Part No., Name, and Description. Also furnish Vehicle Model and Year. Type of Hydraulic Unit and Moldboard Size.

Meyer Products reserves the right, under its continuing product improvement program, to change construction or design details, specifications and prices without notice or without incurring any obligation.

## GENERAL INFORMATION

**CAUTION:** Always disconnect battery before beginning installation.

**DO NOT BURN** holes or **WELD** vehicle frame. This may cause frame failure.

After first use, retighten all mounting bolt connections to specified torque. All mounting bolt connections to be checked periodically for tightness.

Locknuts are furnished **DO NOT** tighten bolts and nuts until installation is complete (unless otherwise specified), then be sure to tighten all attaching parts per specified torque chart.

**NOTE:** It is important that the Meyer harness, all wires from the Meyer light switch, and all other electrical wires be routed around hot or moving engine parts, and any sharp metal. Protection must be provided to guard against wire damage at these points. All excess or loose wires must be neatly secured using wire ties.



Check contents against the parts list to determine all are correct and included, and also to familiarize yourself with them.

**SAFETY PRECAUTIONS** should be used when **Hydraulic Unit is in OPERATION** and plow is in a **RAISED** position. **Lower plow to ground when vehicle is PARKED.**

**OVERHAUL** and **SERVICE INFORMATION** are covered on separate instructions.

Follow these instructions explicitly. Warranty does not apply to a Meyer product which has been negligently or improperly assembled or installed.

### TORQUE CHART FOOT LBS.

Bolt Nut Size	Gr. 2 	Gr. 5 	Gr. 8 
1/4 - 20	4 - 5		
5/16 - 18	9 - 11		
3/8 - 16	17 - 20		
7/16 - 14		26 - 29	
1/2 - 13		42 - 46	60 - 66
5/8 - 11		127 - 141	179 - 198
3/4 - 10		227 - 251	

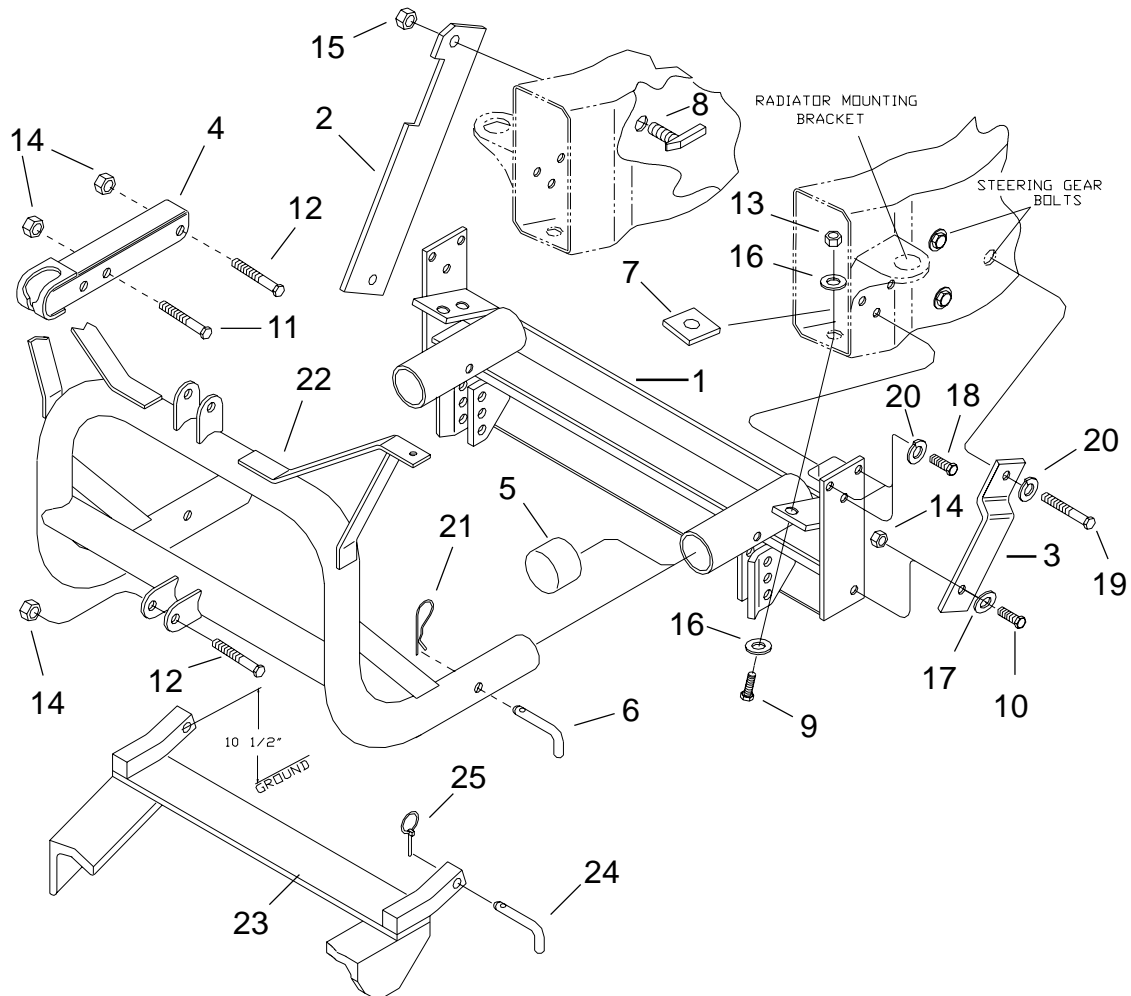

## INSTALLATION INSTRUCTIONS

- A. Remove tow hooks. Retain all hardware. **The tow hooks will not be reinstalled.**
- B. Remove air dam. Retain all hardware. **The air dam will not be reinstalled.**
- C. Remove 3 bolts from both the L.H. (driver) and R.H. (passenger) radiator mounting brackets. These bolts will not be reused.
- D. Position clevis frame (1) over the radiator mounting brackets. Attach clevis frame using M14-2 x 50mm bolts (18), lockwashers (20). **Do not tighten at this time.**
- E. Secure clevis frame (1) to the bottom flange of the vehicle frame using 1/2-13 x 2-1/4" bolts (9), flatwashers (16), spacer (7) and locknuts (13).
- F. Attach the L.H. strap (3) to the clevis frame using 5/8-11 x 1-3/4" bolt (10), flatwasher (17) and locknut (14). Remove the rear steering gear box bolt as per illustration. Retain bolt it will not be reused. Attach strap using M-14 x 2 x 140mm bolt (19), lockwasher (20).
- G. Attach the R.H. strap to the clevis frame using 5/8-11 x 1-3/4" bolt (10) and locknut (14). Raise the strap upward to meet with the vehicle frame. While holding strap tight against the vehicle frame, use the strap (2) as a template to drill a 13/16" hole in the vehicle frame. Attach strap using special bolt (8) and locknut (15) **Note: Before tightening the fasteners, the clevis frame should be pushed back as far as possible under the vehicle.**

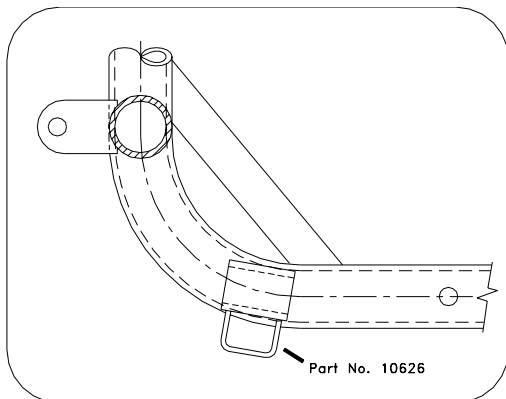
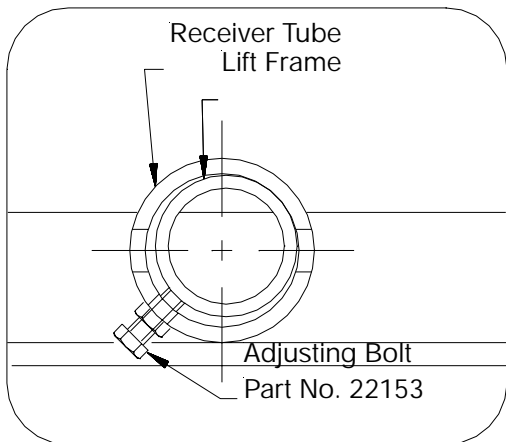

- H. Tighten all fasteners to their proper torque. Tighten bolts in the same order they were assembled to the vehicle.

**Important Notice:** Prior to installation of the lift frame (22), it will be necessary to identify the lift frame being installed. Current production lift frames have additional stops (Part No. 10626) tack welded to the existing stops. (See illustration.) Earlier production lift frames will not have these stops. Depending upon the S.A.F. Carton being installed, additional stops may need to be added or removed.

- I. When installing S.A.F. Carton 16505, lift frame should have the additional stops (Part No. 10626).
- J. When installing S.A.F. Carton 16504, lift frame should **NOT** have the additional stops (Part No. 10626).

**Note:** Before installing lift frame tubing to clevis frame, liberally coat ends of lift frame with chassis grease / anti-seize lubricant.

- K. Install Lift Frame (22) into the tubes on the clevis frame. Turn adjusting bolts in until contact is made with lift frame.

**Caution:** Do not over tighten adjustment bolts. Adjust bolts for minimum clearance between lift frame and receiver tubes while still allowing for ease of lift frame removal. See illustration. Secure lift frame (22) to clevis frame (1) using hinge Pins (6) and hair pin cotters (21).

- L. Attach lift arm (4) to lift frame (22) using 5/8-11 x 3-1/4" bolt (12) and locknut (14). Mount Hydraulic unit to lift frame using 5/8-11 x 3-1/4" bolt (12) and locknut (14), and to lift arm (4) using 5/8-11 x 2-3/4" bolt (11) and locknut (14). **(SEE WARNING)**
- M. Install hydraulic system and snow plow lights per separate instructions.
- N. Pre-Assemble Moldboard Assembly, A-Frame (23), Sector, ect., per separate instructions.
- O. Hook the A-Frame chain to the Lift Arm (4) allowing sufficient slack to enable the Moldboard to follow ground contour while plowing.

**Note:** When the lift frame module (22) is removed from the vehicle, the insides of the clevis frame (1) receiver tubes and outside ends of the lift frame should be coated with chassis grease/anti-seize lubricant and the protective receiver tube caps (5) install over the clevis frame receiver tubes.

Meyer Products assumes no responsibility for installations not made in accordance with these instructions.